



VACUUM-JACKETED PIPING IN LIQUID OXYGEN SERVICE

AIGA 106/19

ASIA INDUSTRIAL GASES ASSOCIATION

No 2 Venture Drive, #22-28 Vision Exchange, Singapore 608526

Tel : +65 6705 5642 • Fax : +65 6863 3307

Internet: www.asiaiga.org



VACUUM-JACKETED PIPING IN LIQUID OXYGEN SERVICE

As part of a programme of harmonisation of industry standards, the Asia Industrial Gases Association (AIGA) has issued publication 106, *Vacuum-Jacketed Piping in Liquid Oxygen Service*, jointly produced by members of International Harmonisation Council and originally published by Compressed Gases Association Inc, (CGA) as G-4.15, *Vacuum-Jacketed Piping in Liquid Oxygen Service*.

This publication is intended as an international harmonised standard for the worldwide use and application of all members of the Asia Industrial Gases Association (AIGA), Compressed Gas Association (CGA), European Industrial Gases Association, and Japan Industrial and Medical Gases Association (JIMGA). Each association's technical content is identical, except for regional regulatory requirements and minor changes in formatting and spelling.

Disclaimer

All publications of AIGA or bearing AIGA's name contain information, including Codes of Practice, safety procedures and other technical information that were obtained from sources believed by AIGA to be reliable and/ or based on technical information and experience currently available from members of AIGA and others at the date of the publication. As such, we do not make any representation or warranty nor accept any liability as to the accuracy, completeness or correctness of the information contained in these publications.

While AIGA recommends that its members refer to or use its publications, such reference to or use thereof by its members or third parties is purely voluntary and not binding.

AIGA or its members make no guarantee of the results and assume no liability or responsibility in connection with the reference to or use of information or suggestions contained in AIGA's publications.

AIGA has no control whatsoever as regards, performance or non performance, misinterpretation, proper or improper use of any information or suggestions contained in AIGA's publications by any person or entity (including AIGA members) and AIGA expressly disclaims any liability in connection thereto.

AIGA's publications are subject to periodic review and users are cautioned to obtain the latest edition.

Table of Contents

1	Introduction	1
2	Scope and purpose	1
3	Definitions	1
3.1	Publication terminology	1
3.2	Technical definitions	2
4	General hazards and requirements	2
4.1	Oxygen hazards.....	2
4.2	Hazards and requirements for vacuum-jacketed piping systems in liquid oxygen service	2
5	Design	3
5.1	General vacuum-jacketed piping description	3
5.2	Vacuum-jacketed piping design considerations	5
6	Oxygen compatibility	14
6.1	Selection of materials	14
6.2	Cleaning.....	14
7	Fabrication, testing, quality assurance/quality control, and shipping.....	14
7.1	Fabrication, testing, and quality assurance/quality control requirements.....	15
7.2	Shipping requirements.....	15
7.3	Site installation.....	16
8	Operations and maintenance.....	16
8.1	General considerations.....	16
8.2	Inspection	16
8.3	Vacuum reading.....	17
8.4	Maintenance	18
8.5	Equipment isolation	18
8.6	Management of change.....	18
8.7	Protecting open systems when piping or piping components have been removed	18
8.8	System blowout after major maintenance	18
8.9	Change of service.....	19
9	References.....	19
10	Additional references.....	20
	Appendix A—List of typical suitable materials (Informative).....	21

Tables

Table 1	Examples of vacuum jacketed pipe weight per length.....	13
---------	---	----

Figures

Figure 1a	Example of vacuum jacketed piping - Cutaway view.....	4
Figure 1b	Example of vacuum-jacketed piping - Cutaway view	4
Figure 2	Example of a vacuum-jacketed piping run in service	5
Figure 3	Internal and external bellows	7
Figure 4a	Cutaway of a typical bayonet design	8
Figure 4b	Cutaway of a typical bayonet design	9
Figure 5	Example of a V band clamp design	10
Figure 6	Example of flanged connection.....	10
Figure 7	Typical vacuum field closure cutaway view	11
Figure 8	Example of a vacuum jacketed riser.....	12
Figure 9	Examples of well supported bayonet connections.....	13
Figure 10	Examples of hangar and roller supports	14
Figure 11	Example of an iced bayonet connection	17

1 Introduction

In recent years, the increase in the size and production capacity of air separation plants has led to a corresponding increase in the capacity of liquid oxygen storage and transfer installations at production sites.

Multiple violent ruptures of vacuum-jacketed piping systems used in liquid oxygen service have been experienced in the industrial gas industry. These incidents have occurred due to a variety of causes including:

- Liquid oxygen leak into the annular space followed by reaction with incompatible material(s), for example, contaminants, palladium oxide getter, activated charcoal;
- Liquid oxygen leak into the annular space followed by contact with materials that have not been properly cleaned for oxygen service; and
- Liquid oxygen leak into the annular space followed by rapid over pressurization of the annular space.

The intent of this publication is to ensure that a minimum, uniform level of safety is provided throughout the industrial gas industry for the protection of the public and industry employees.

2 Scope and purpose

This publication addresses vacuum-jacketed piping used in any stationary industrial gases applications including air separation plants, other industrial gases facilities, and customer installations in liquid oxygen service. This publication provides guidance to those persons directly associated with the design, installation, operation, and maintenance of vacuum-jacketed piping systems used to transfer liquid oxygen. The user is cautioned that this publication is not a complete design handbook and does not do away with the need for competent engineering judgment and interpretation. It is suggested that the user review any special problems or concerns with the liquid oxygen supplier and/or vacuum-jacketed piping manufacturer who can provide guidance. This publication does not supplant, but is intended to complement, national and local regulations and codes of practice.

3 Definitions

For the purpose of this publication, the following definitions apply.

3.1 Publication terminology

3.1.1 Shall

Indicates that the procedure is mandatory. It is used wherever the criterion for conformance to specific recommendations allows no deviation.

3.1.2 Should

Indicates that a procedure is recommended.

3.1.3 May

Indicates that the procedure is optional.

3.1.4 Will

Is used only to indicate the future, not a degree of requirement.

3.1.5 Can

Indicates a possibility or ability.

3.2 Technical definitions

3.2.1 Non-metallic material

Any material, other than metal, or any composite material in which the metal constituent is not the most easily ignited component and for which the individual constituent cannot be evaluated independently (see ASTM G63, *Standard Guide for Evaluating Nonmetallic Materials for Oxygen Service* [1]).¹

3.2.2 Vacuum-jacketed piping specifier

Individual or organization that has responsibility for defining technical and/or procurement requirements for vacuum-jacketed piping systems.

3.2.3 Getter

Reactive material that removes trace contaminants from a gas.

3.2.4 Annular space

Volumetric space between the inner pipe and outer jacket that contains insulation materials and is evacuated to lessen heat flux.

4 General hazards and requirements

4.1 Oxygen hazards

Oxygen is not flammable but supports and accelerates combustion. Oxygen concentrations greater than 23.5% create fire hazards but not asphyxiation hazards. Flammable materials, including some materials that are normally relatively non-flammable in air, burn very rapidly in high oxygen concentrations. As concentrations increase greater than 23.5% oxygen, ease of ignition of clothing increases dramatically. Once ignited by even a relatively weak ignition source such as a spark or cigarette, clothing can burst into flames and burn rapidly. Greater than 40% oxygen, the fibres on clothing and body hair and oil are subject to flash fire when ignited, which spreads rapidly over the entire exposed surface. For additional information on oxygen hazards, see AIGA 005, *Fire Hazards of Oxygen and Oxygen-Enriched Atmospheres* [2].

An oxygen hazard analysis is a method used to evaluate risk of fire in an oxygen system. It assesses the probability of ignition or consequence of ignition (ignition versus sustained burning based on operating conditions). It can be used to select materials for new designs or to evaluate the compatibility of materials. In general, acceptance criteria for materials in a given application depend on two key factors, ignitability and flammability. For more information on oxygen hazard analysis and risk assessment, see AIGA 094, *Design, Manufacture, Installation, Operation, and Maintenance of Valves Used in Liquid Oxygen and Cold Gaseous Oxygen Systems* [3].

4.2 Hazards and requirements for vacuum-jacketed piping systems in liquid oxygen service

Hazards that relate to the use of vacuum-jacketed piping systems in liquid oxygen service include:

- Noncompatible adsorbent—Nonoxygen compatible adsorbent shall not be used in the annular space due to potential high reactivity with any oxygen that leaks into the annular space;
- Oxygen leaking into the annular vacuum space can react with any non-metallic components within the annular space including internal supports. Liquid oxygen can also rapidly vaporize and lead to an over pressurization of the vacuum jacket;
- Noncompatible annular insulation materials—These materials can react with oxygen that leaks into the annular space. Annular insulation materials shall be hydrocarbon-free and compatible with oxygen;

¹ References are shown by bracketed numbers and are listed in order of appearance in the reference section.

- Piping and component contamination—All piping and components, including the annular space, that can come into contact with oxygen (for example, in the event of an inner pipe leak) shall be cleaned to meet oxygen cleanliness requirements (see AIGA 012, *Cleaning of Equipment for Oxygen Service* [4]);
- Oxygen leaking from the inner pipe into the annular space can react with getter material (for example, palladium oxide). Additionally, if the getter material leaks from its container and comes into contact with aluminium, subsequent oxygen exposure can lead to ignition of the aluminium wrapping material; and
- Liquid oxygen leaking into the annular space or the gap between the male/female parts of the bayonet and being totally evaporated can, in the long term, enrich hydrocarbons on the metal surface until an ignition occurs. In addition, an uncontrolled pressure release can occur due to liquid evaporation.

5 Design

5.1 General vacuum-jacketed piping description

Piping systems that store and convey cryogenic fluids present unique considerations. From a safety standpoint, the extremely low temperature of cryogenic fluids exposes the user to potential serious irreversible injury. From an operational standpoint, excessive heat in-leak and pressure loss, both which effect fluid phase quality, can prevent efficient operation. Poorly insulated lines are not cost effective and ice or frost that develops can cause water damage to the surrounding area and falling ice can damage equipment. Vacuum-jacketed piping with radiation shielding safely addresses these concerns. The outer jacket remains at near ambient temperature while providing the most efficient and stable thermal insulating effect available.

Because the majority of these piping systems are installed in the common workplace, safety regulations and general liabilities shall be considered. Piping shall be designed and manufactured in accordance with American Society of Mechanical Engineers (ASME) B31.3, *Process Piping* or an equivalent piping code that takes into account temperature, pressure, fluid, and service conditions to which the piping will be operated thereby providing the common safety guide for engineering design, fabrication, and testing [5].

To produce this class of specialty piping, a well-regulated production facility with qualified personnel is essential to perform fabrication, leak checking, examination, and other quality control functions. When field assembly or modification is required, care is needed to maintain the vacuum, or to re-establish a quality vacuum in the field, use only qualified personnel.

Figure 1a and 1b show two examples of a section of vacuum-jacketed piping. Figure 2 shows an example of vacuum-jacketed piping in service.

5.1.1 Vacuum superinsulation

System of thermal insulation that includes:

- Double shell insulation space (annular space) where static vacuum is limiting heat transfer by conduction and convection;
- Blanket of alternate layers of highly reflecting shields and insulating spacers to prevent heat transfer by radiation as well as conduction between shields; and
- Adsorbent placed in the vacuum space in order to achieve an adequate level of vacuum at low temperature by adsorption of residual gases and moisture.

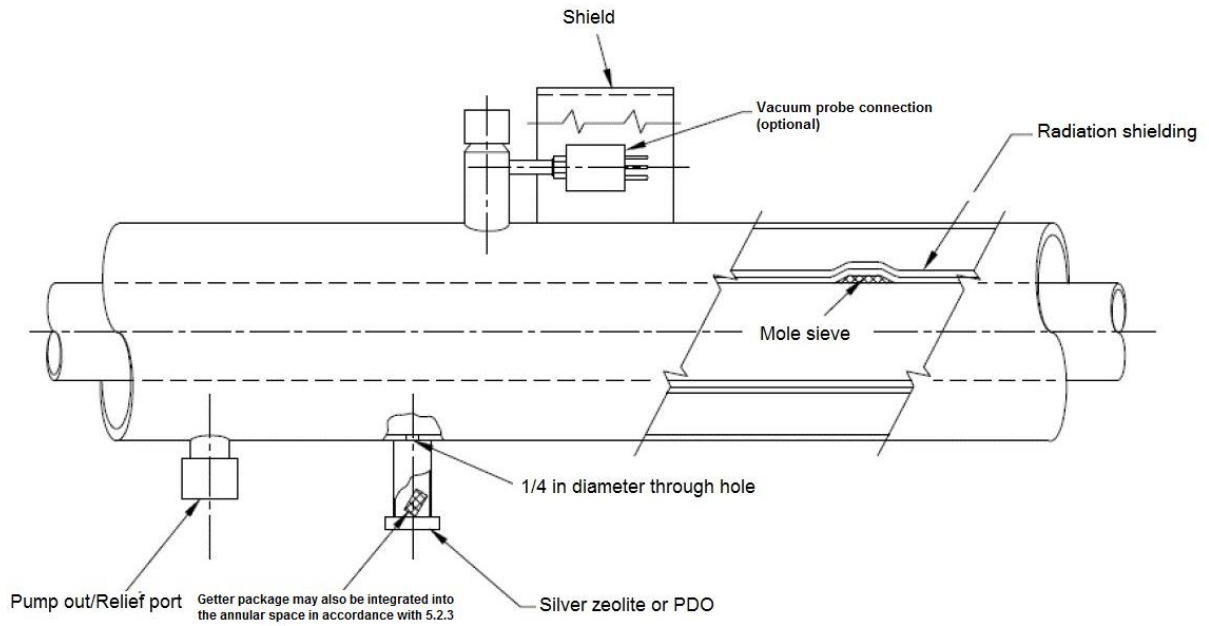
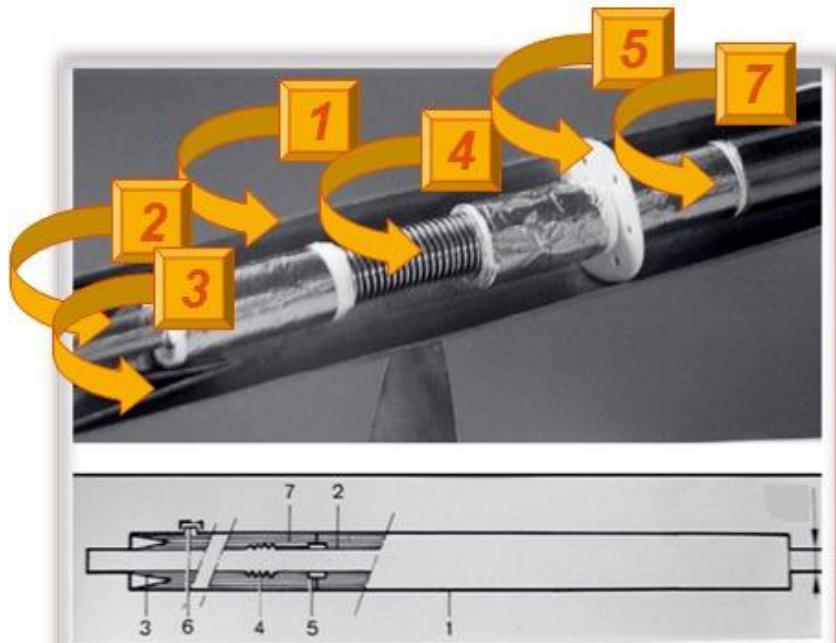

Figure 1a Example of vacuum jacketed piping - Cutaway view



1	Outer jacket
2	Inner pipe
3	Thermal barrier
4	Expansion bellow
5	Spacer
6	Vacuum port/relief port (not shown in photo)
7	Radiation shielding
NOTE The getter and molecular sieve are not shown in this figure.	

Figure 1b Example of vacuum-jacketed piping - Cutaway view



Figure 2 Example of a vacuum-jacketed piping run in service

5.2 Vacuum-jacketed piping design considerations

Vacuum-jacketed piping shall be configured with the following design considerations.

5.2.1 Inner pipe

- The design and manufacturing of the vacuum-jacketed piping shall be in accordance with ASME B31.3 (or equivalent piping code) to meet the maximum allowable working pressure (MAWP) and fluid requirements [5];
- Inner pipe material and fittings, including flanges, forged fittings, elbows, tees and reducers, and compensation devices such as bellows or flexible hoses shall be of suitable material and thickness for the cryogenic temperatures, MAWP, and fluids to which it will be exposed. Fittings shall comply with ASTM A403, *Standard Specification for Wrought Austenitic Stainless Steel Piping Fittings* and ASTM B16.9, *Factory Made Wrought Buttwelding Fittings* or equivalent code [6, 7]. See Appendix A for a list of typical materials; and
- A flexibility analysis shall be performed to consider the thermal compensation of the inner pipe due to thermal contraction of the inner pipe (selection of bellows, identification of the fixed-point supports, and sliding supports). The expansion joints (bellows) shall be installed according to *Standards of the Expansion Joint Manufacturers Association, Inc.* [8]. See 5.2.4. The flexible hoses shall be designed and manufactured according ASME B31.3 or an equivalent code [5]. See 5.2.6. The bellows should be dimensioned for a minimum of 1000 cycle loads. The designed expansion length of the bellows should only reach up to 80% of its maximum allowable expansion.

The available bending length of the process tubes shall be sufficient so that the bending forces are within material specification. This bending length depends on the stiffness of the tube. To reduce the forces, prestressing of the tube lengths equal to half the contraction may be introduced during assembly.

The inner pipe shall be supported within the vacuum outer jacket by a support system designed to:

- absorb thermal loads on the inner pipe when partially or completely filled with product;
- be compatible for liquid oxygen application;
- minimize heat losses;
- withstand mechanical and dynamic loading during normal operating conditions, shipping, and handling; and
- meet seismic requirements while in service.

5.2.2 Vacuum jacket

The vacuum jacket shall be designed to withstand the complete dead weight (vacuum-jacketed + inner process pipe), the loads transmitted by the inner process pipe, and the atmospheric conditions including variation of temperature, wind, snow, ice, and seismic. The buckling and collapse shall be checked while the annular space is under vacuum. The vacuum jacket is not considered as pressure equipment. The vacuum jacket can be designed in accordance with *ASME Boiler and Pressure Vessel Code*, Section VIII or equivalent code for an internal vacuum and external atmospheric pressure with the assembly at ambient temperature (for example, the use of fillet weld is used on the vacuum jacket but not accepted by ASME or pressure vessel codes) [9]. Design criteria include:

- Vacuum jacket material shall be of a suitable material and thickness for the temperatures, pressures, and fluids to which it will be exposed. See Appendix A for typical materials;
- Vacuum jacket elbows may be a mitred design or may use an outer pipe fitting. Jacket tees can be a branch tee design or made from a standard tee fitting. Elbows and tees are typically manufactured from the same material as the vacuum jacket. See Appendix A for typical materials;
- Annular space relief device (typically incorporated within the vacuum pump out port to minimize penetrations to the vacuum jacket) is required on the vacuum jacket to prevent over pressurization of the annular space in case of internal leakage. See 5.2.6 for more details;
- Vacuum pump out port shall be oriented to not block (by external obstacle such as a wall, support, etc.) the ejection of the plug-in case of leakage and pressurization of the annular space and also to allow to be visible for maintenance and periodic control;
- Vacuum/relief ports and perlite fill connections shall be accessible after erection at site so that annular space maintenance can be accomplished, if required; and
- Vacuum jacket shall not be used as a secondary containment vessel.

5.2.3 Annular space

Internal supports in the vacuum annular space shall be designed to:

- absorb dead weight and thermal loads on the inner pipe when partially or completely filled with product;
- minimize heat leakage;
- withstand loading during shipping; and
- withstand seismic loadings after installation.

Attention shall be paid to internal supports at each elbow where axial loading can be higher and additional support necessary.

Insulating materials and internal supports used shall be oxygen compatible. See Appendix A for typical materials.

Materials used in the vacuum annular space shall be oxygen compatible. The use of aluminized or aluminium tape type adhesives shall be approved through a risk assessment. If approved, they shall only be used in small quantities where necessary to attach insulation around the inner pipe to prevent it from moving.

To maintain low vacuum, materials such as molecular sieve and getters shall be used to remove vacuum contaminants released by out gassing during the lifetime of the pipe. Molecular sieve adsorbs all molecules larger than hydrogen. The getter material converts free hydrogen into water that the molecular sieve can then adsorb.

Each vacuum space shall be equipped with an evacuation port and annular space relief device (typically provided as a combination device). A vacuum transducer or pressure gauge should be installed for monitoring the vacuum level without breaking the vacuum annulus. Vacuum checking may also be done at the pump out/relief port nozzle if no vacuum probe connection is available.

A getter made of palladium oxide in vacuum-jacketed piping in liquid oxygen service shall only be used if the getter is:

- contained in a canister external to the outer jacket that communicates with the annular space;
- in a totally enclosed sintered brass canister contained within the annular space; or
- completely enclosed by an oxygen compatible fiberglass paper that is then enclosed in a fine mesh brass screen.

A sufficient gap shall exist between the canister and the aluminium wrapping material of the superinsulation to avoid contact.

All other getter materials shall be contained in fiberglass insulating paper inside of a fine copper mesh screen or embedded in sintered brass or contained by a method proposed by the supplier and approved by the user.

WARNING: *If palladium oxide is used in liquid oxygen service, oxygen can leak from the inner pipe and react with the getter material. Additionally, if the getter material leaks from its container and comes into contact with aluminium, subsequent oxygen exposure can lead to ignition of the aluminium wrapping material.*

WARNING: *Activated charcoal shall not be used as an adsorbent in the annular space due to its explosive reaction when in contact with liquid oxygen (see Section 1) [10].*

5.2.4 Expansion bellows

Expansion bellows may be located on the inner or outer line to compensate for thermal contraction. Figure 3 shows an example of internal and external expansion bellows. Expansion bellows shall be designed to absorb thermal contraction of the inner pipe when operating at low temperatures. See Appendix A for typical materials. If bellows are subject to a large axial mechanical loading, care shall be taken when designing bellows to provide axial support or movement constraints that will accommodate the axial loading without damage to the bellows or piping. See 5.2.1.

The installation of the expansion bellows shall be in accordance with *Standards of the Expansion Joint Manufacturers Association, Inc.*, or equivalent [8].

Overall system flexibility can be addressed by adding expansion loops, specifically when external bellows are used. For vacuum jackets with external bellows, external pipe supports shall allow the piping system to move in order to relieve thermal expansion. See 5.2.8.

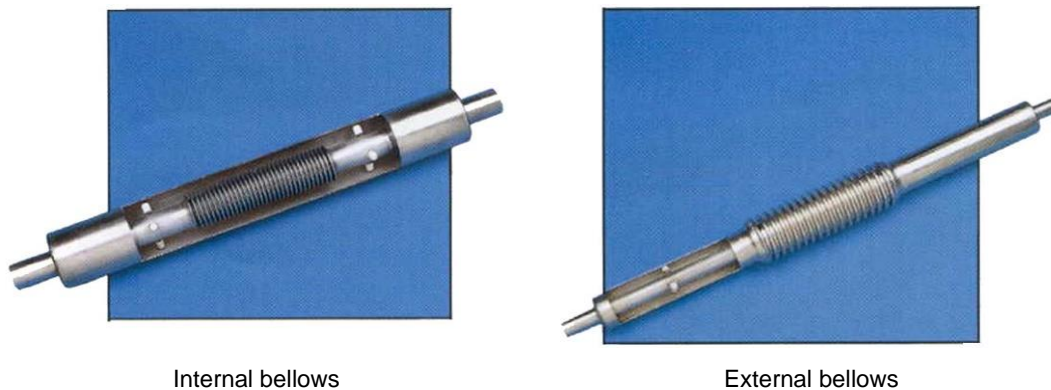

Figure 3 Internal and external bellows

5.2.5 Braided flexible hose

Braided flexible hose may be used to relieve stress of an installed vacuum-jacketed piping system. If braided flexible hoses are used, they should be used in an offset motion design to relieve stress but should not be used to relieve stress in the axial direction.

Braided flexible hoses shall be designed and manufactured according ASME B31.3 and BS 6501-1, *Metal hose assemblies. Guidance on the construction and use of corrugated hose assemblies or equivalent* [5, 11].

5.2.6 Types of vacuum-jacketed piping connections

5.2.6.1 General requirements

Verify that the type of connection meets the system MAWP requirements.

Verify that the materials are compatible with cryogenic fluid. Ensure that the connection is leak-free after installation and while in operation.

5.2.6.2 Bayonets

Cutaways of typical bayonet designs are shown in Figures 4a and 4b. The flange connection on the outer pipe allows higher axial loading. Designs where axial forces for inner seal and flange gaskets can be adjusted independently reduces the risk of leakage into the annular space. If not installed correctly, bayonet connections can lead to leakage into the gap between male and female parts. In liquid oxygen service, this has led to dry boiling and hydrocarbon accumulation.

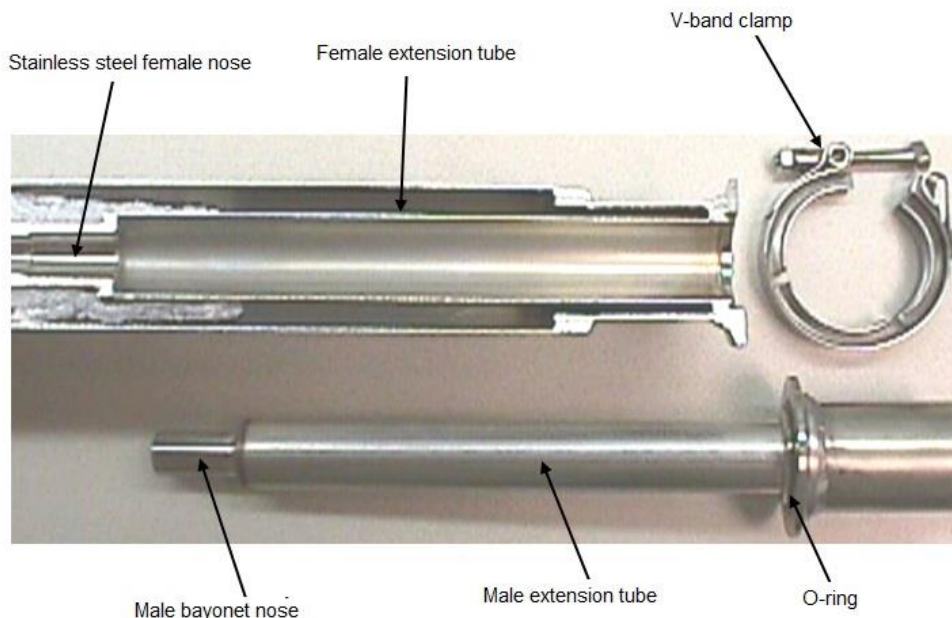

Figure 4a Cutaway of a typical bayonet design

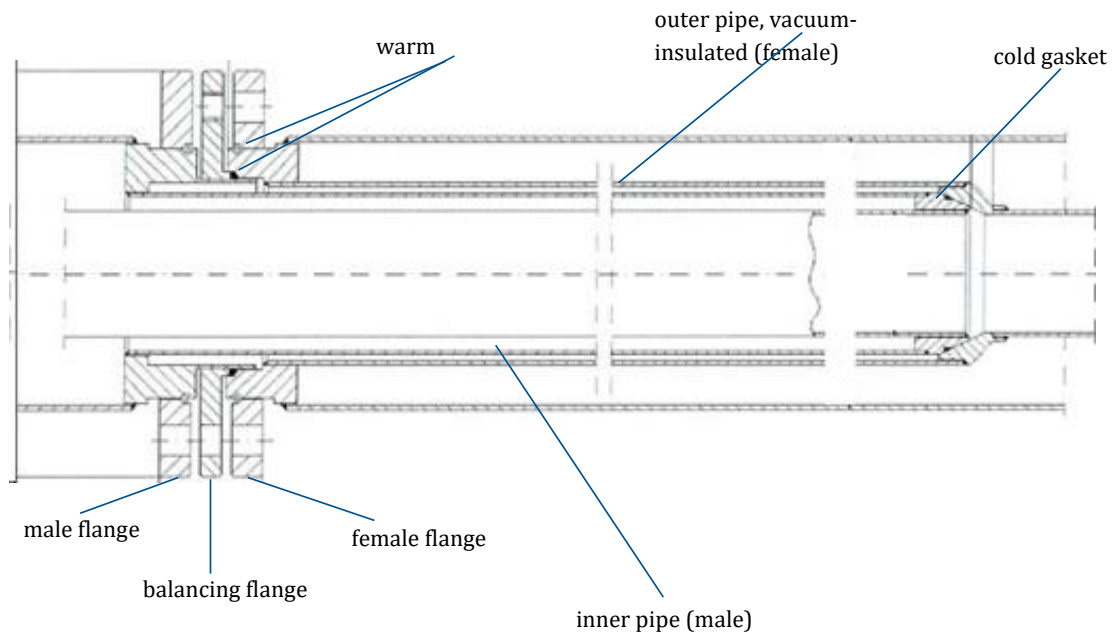

Figure 4b Cutaway of a typical bayonet design

The design of all bayonet connections should ensure that they are not subjected to icing and leakage of liquid oxygen due to heat losses and the vaporization of cryogenic liquid.

Various bayonet designs can be used in a vacuum-jacketed piping system. They include but are not limited to:

- Dissimilar metals—The dissimilar metal design operates by incorporating dissimilar metal technology in the construction. The male nose of the bayonet is typically constructed of Invar and the female nose is constructed of stainless steel. At operating temperature, the stainless-steel female nose contracts over the male nose to provide a tight liquid seal (not considered a pressure seal);
- Similar metals close tolerance—Close tolerance bayonets create a liquid seal by designing the bayonets so that a very close tolerance is maintained between the male and female extension tubes, creating a gas pocket in that area. Stainless steel 300 series is commonly used for this design; and
- Polytetrafluoroethylene (PTFE) nose seal designs—This design uses a PTFE seal at the male bayonet nose. Stainless steel 300 series is commonly used for this design as well.

Each bayonet will have an O-ring as a secondary seal at the warm outer flange to prevent gas leakage at the bayonet connection. Standard O-ring material is referenced in Appendix A.

Each bayonet connection shall be secured with a V-band clamp or using a bolted flange design. See Figure 5.

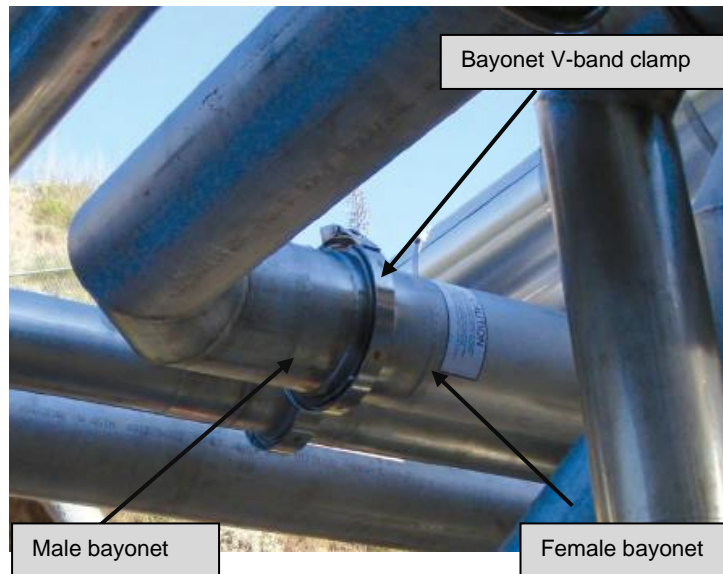

Figure 5 Example of a V band clamp design

5.2.6.3 Flanged connections

When used, flanged joints connecting to nonvacuum-insulated equipment or piping shall terminate in ASME B31.3 or equivalent stainless-steel flanges [5].

See Figure 6.

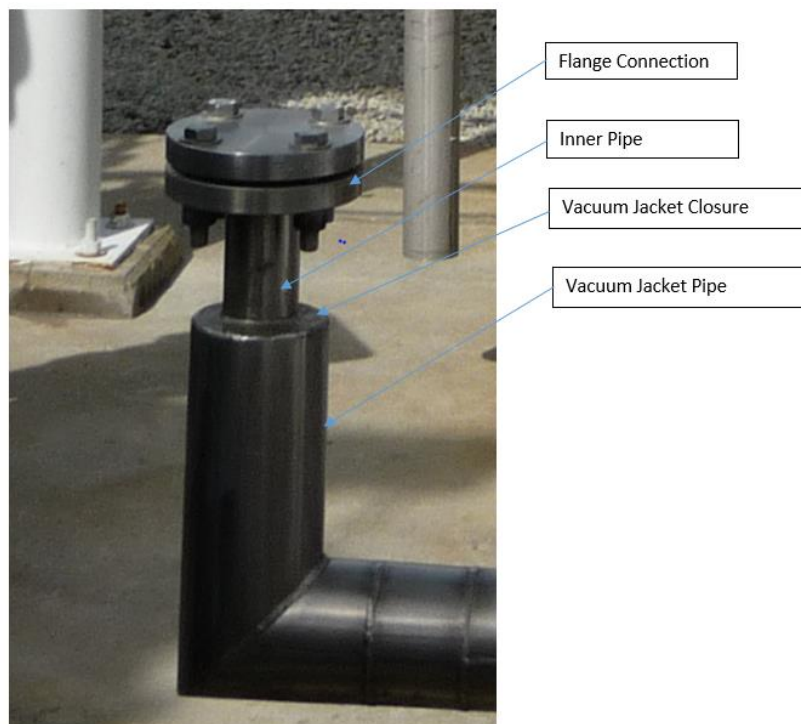

Figure 6 Example of flanged connection

5.2.6.4 Field welded connections

Field welded connections are typically undertaken for large diameter piping (for example, 3 in inner pipe or greater) and for longer run piping. However, field welded connections may also be used for smaller diameter and shorter run piping to avoid the possibility of leaks.

These connections provide a butt welded inner pipe with field closures using vacuum or using perlite or other suitable insulation. The advantages include eliminating a potential leak point at the bayonet connection.

NOTE The field weld is a pressure bearing weld and as such may have code requirements such as the use of a certified welder and weld procedure, pressure testing, non-destructive examination (NDE), and third-party inspection.

For field closures using a vacuum cover design:

- a) Install molecular sieve, getter (see 5.2.3), and multilayer insulation into the annular space of the field joint;
- b) Weld the cover to the weld pad/outer jacket with a fillet weld. Weld the entire circumference of each cover to weld pad joint; and
- c) Leak check the assembled field joint using helium mass spectrometry to ensure no leaks. Pull vacuum on the field joint can.

Figure 7 shows the cutaway view of a vacuum field closure.

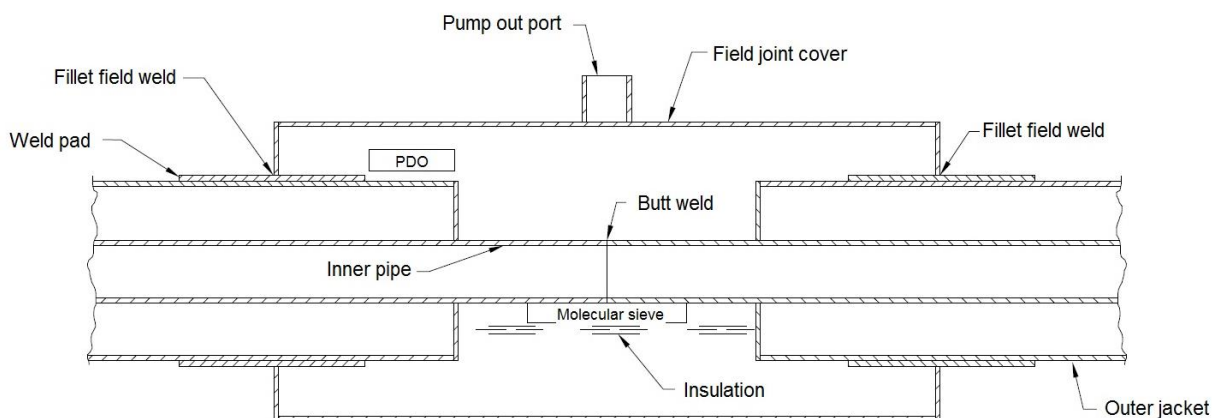

Figure 7 Typical vacuum field closure cutaway view

5.2.7 Pressure relief devices

The vacuum-jacketed piping system shall incorporate relief valves as necessary to protect the inner piping from overpressure that can be generated either by the upstream or downstream process or by liquid entrapment (for example, between two isolation valves in a closed position).

The calculation criteria of thermal relief valves should be verified such as in case of loss of vacuum of one or more segments of the liquid oxygen vacuum-jacketed piping system. For specific applications, the calculation criteria may also consider the loss of vacuum and fire based on a corresponding risk assessment.

The thermal relief valve should not be the primary means of controlling the pressure in the inner pipe. The use of a pressure regulator, a second redundant safety valve (staggered set pressure), instrumented control loops, or a procedure to prevent blocking-in of liquid should be considered where necessary.

Relief valves should have a seal to prevent uncontrolled dismantling or modification, shall be designed in accordance with AIGA 094, and shall be installed between points at which the flow can be stopped (valves, check valves, regulators, etc.) [3]. If the relief valves are installed on vacuum-jacketed portion of the piping system, vacuum-jacketed risers shall be used to reduce the heat input and potential for frost. See Figure 8. Oxygen relief valves should be vented to a safe location.

An annular space relief valve is required to prevent over pressurization of the annular space. Typical construction incorporates the annular space relief valve with the pump out port. Every section of vacuum

shall have an annular space relief valve. The typical orifice size for annular space relief valve is 1/2 in or greater. The vacuum-jacketed piping manufacturer shall be responsible for adequately sizing the annular space relief valve. Jacket relief devices using cylindrical plugs that can be ejected when relieving occurs shall be fitted with plug restraints or deflector shields to ensure personnel safety. Each perlite fill coupling shall also include a pressure relief device.



Figure 8 Example of a vacuum jacketed riser

5.2.8 Piping supports

When supporting the piping, the following needs to be considered:

- Adequate support span (distance between supports);
- Weight of the piping that is being supported. Table 1 gives approximate weights per pipe length;
- Supports should be placed close enough to handle the weight loads, depending on the load capacity of the support system being used. If bayonets are used, each section of pipe should have a minimum of two supports to relieve any stress on the bayonets. Figure 9 shows installations where the bayonet connections are well supported;
- Support system used shall account for the possibility of movement of the system. The installation should provide means of support that accommodates expansion/contraction due to temperature change; and
- For external bellows piping systems, the relative movement between the inner pipe and outer jackets is taken up in the external bellows. As such, the outer jacket will move by design. A support system (such as rollers, hangers, etc.) shall be used to allow this movement and prevent damage of the pipe. Do not locate supports directly under external bellows. Examples of roller and hanger supports are shown in Figure 10.

Table 1 Examples of vacuum jacketed pipe weight per length

Pipe size	Approximate weight per pipe length with liquid oxygen
1/2 in inner line (2 in outer jacket)	3 1/4 lb/ft
1 in inner line (3 in outer jacket)	5 lb/ft
2 in inner line (4 in outer jacket)	8 lb/ft
3 in inner line (5 in outer jacket)	15 1/4 lb/ft
4 in inner line (6 in outer jacket)	21 lb/ft
Greater than 4 in inner line	Consult manufacturer

NOTE These weights are only approximate and can vary due to the presence and number of valves, actuators, manufacturer, etc.

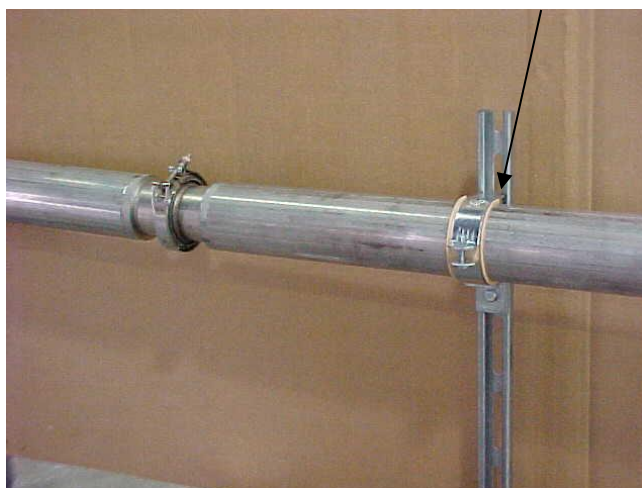
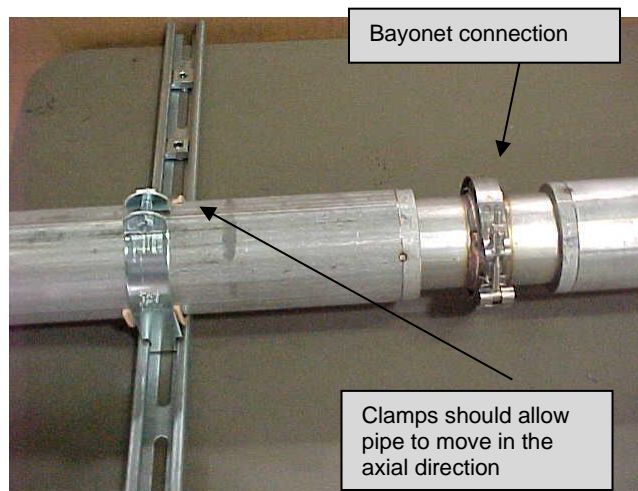

Figure 9 Examples of well supported bayonet connections



Figure 10 Examples of hangar and roller supports

6 Oxygen compatibility

6.1 Selection of materials

For suitable materials used in vacuum-jacketed piping, see Appendix A.

Non-metallic materials used within vacuum-jacketed piping systems shall meet the requirements of ASTM G63 [1].

When valves are used, selection of materials in contact with the process fluid shall be in accordance with AIGA 094 [3].

For more information on oxygen compatibility, see ASTM G63, ASTM G72, *Standard Test Method for Autogenous Ignition Temperature of Liquids and Solids in a High-Pressure Oxygen-Enriched Environment*, ASTM G88, *Standard Guide for Designing Systems for Oxygen Service*, and ASTM G86, *Standard Test Method for Determining Ignition Sensitivity of Materials to Mechanical Impact in Ambient Liquid Oxygen and Pressurized Liquid and Gaseous Oxygen Environments* [1, 12, 13, 14].

Avoid the use of lubricants, where possible. Where lubricants are used such as for O-rings, ensure they are compatible for use in oxygen service.

6.2 Cleaning

Process fluid contact surfaces for the inner pipe, valves, flex hoses, etc. shall be cleaned in accordance with AIGA 012 [4]. These requirements apply to both shop and field cleaning efforts.

Annular space surfaces shall be cleaned per AIGA 012 and shall be free of contaminants, including hydrocarbons and other compounds that exhibit low vapor pressures [4].

For more information on cleaning for oxygen service, see ASTM G93, *Standard Practice for Cleaning Methods and Cleanliness Levels for Material and Equipment Used in Oxygen-Enriched Environments* [15].

7 Fabrication, testing, quality assurance/quality control, and shipping

A joint quality assurance/quality control (QA/QC) plan shall be developed by the vacuum-jacketed piping specifier, manufacturer, and installation contractor.

A comprehensive testing QA/QC report shall be documented and provided with the vacuum-jacketed piping.

7.1 Fabrication, testing, and quality assurance/quality control requirements

Vacuum-jacketed piping shall use a manufacturing and installation sequence that provides for cleaning, inspection, and testing.

All pipe welding and brazing shall be performed in accordance with welding and brazing procedures and by welders and brazers qualified to the procedures in accordance with the piping code as defined in the project specification.

The applicable piping code (ASME B31.3 or equivalent) should be used for the type and quantity of testing required [5].

For example, NDE can be conducted:

- to verify weld integrity;
- to verify inner butt weld integrity (X-ray testing);
- to verify vacuum jacket integrity (penetrant testing);
- to verify piping integrity (pressure testing); and
- for critical applications (thermal shock using liquid nitrogen testing).

Verify that the vacuum-jacketed piping is cleaned for oxygen service per AIGA 012 and per the vacuum-jacketed piping specifier [5]. In addition to being trained in work safety knowledge, personnel who install vacuum-jacketed piping systems in oxygen service shall also have specific training and understanding of oxygen safety requirements.

During the vacuum pump down period, each pipe spool piece shall be heated through the inner pipe to a minimum temperature of 121 °C (250 °F) to accelerate out gassing, but not to exceed the maximum temperature limits of the components within the piping system. After pump down, each spool piece vacuum chamber shall successfully pass a mass spectrometer leak detection test using a helium mixture as the leak detection tracer gas. A successful test shall show no helium leakage with the mass spectrometer sensitivity set at 0.987×10^{-8} mb.l.s⁻¹ as a minimum and operated at a pressure of 5 microns of mercury absolute or less.

After completion of the helium leak test, each pipe spool piece vacuum chamber should successfully pass a standing vacuum retention test for a minimum time period of two days at ambient temperature measured at least daily. The stability of the vacuum is registered over 24 hours. The static vacuum shall be less than or equal to 5.10^{-4} mbar.

The recommended minimum specified vacuum level acceptance criteria is:

- Vacuum level rises less than 2 microns (2.6×10^{-3} mbar) per day for 2 days followed by a no rise period with a final level of no more than 15 microns (2×10^{-2} mbar). A steady increase throughout the retention period is not acceptable; and
- Spools with vacuum levels between 15 microns and 35 microns (2×10^{-2} to 4.6×10^{-2} mbar) may be subjected to additional retention testing as well as cold shocking at the option of the vacuum-jacketed piping specifier.

The vacuum retention test and helium leak test reports shall be available.

For each bayonet connection, the manufacturer typically measures the gap between the male and female halves. Gap values shall meet the tolerances to ensure proper installation and operation to meet design requirements.

7.2 Shipping requirements

It is important to support vacuum-jacketed piping during shipment to prevent damage to internal components of the piping. The piping shall also be sealed at all openings to prevent contamination.

The bellows on the outer jacket shall be braced and restrained from flexing during shipment. Bayonet ends and pump out ports/gauge tubes shall also be protected from damage during shipping.

7.3 Site installation

Cold oxygen piping and piping components shall be cleaned for oxygen service before installation and cleanliness shall be maintained thereafter. If any contamination occurs during installation, recleaning and inspection are required. Care shall be taken that all traces of the cleaning agent have been removed from the system as the cleaning agent could have accumulated at low points and dead ends. Piping system installation shall be carried out by contractors approved in their particular discipline (for example, mechanical, civil, instrumentation) in accordance with the design drawings and specifications. Procedures in accordance with the work instructions of the manufacturer shall be made available to technicians and supervisors.

Vacuum-jacketed piping connections shall be installed in the correct direction. This information shall be provided to the installer(s).

Vacuum-jacketed piping in liquid oxygen service should have a positive slope in flow direction of approximately 3 % to 5 %. Where local high or low points cannot be avoided, a drain or vent is required.

The following shall be considered for site installation of vacuum-jacketed piping:

- Ensure that the specified components have been delivered by checking purchasing documents;
- Check that the packaging is intact;
- Segregate oxygen components and maintain packaging integrity during storage;
- Supervised handling of the components is only by personnel trained for oxygen equipment installation to avoid issues such as early unpacking, recontamination by greasy fingers, dust, mechanical damage during installation, etc.;
- Before installation, qualified personnel shall inspect the components at both the inlet and outlet ends and at all accessible points to verify the cleanliness of the oxygen wetted surfaces;
- Correct torque and bolting protocols for all bolting flanges;
- Gaskets—cleanliness, storage, types for different pressure applications;
- As preparation for welding or brazing, heat sensitive parts such as soft seals and gaskets should be removed when close to the heat source;
- Quality check procedure for correct reassembly;
- Process of site construction/site machining—cleanliness and all standards are kept; and
- Cleaning before commissioning, avoid contamination from the piping system.

8 Operations and maintenance

8.1 General considerations

In addition to being trained in work safety knowledge, personnel who operate and maintain vacuum-jacketed piping systems in oxygen service shall also have specific training and understanding of oxygen safety requirements.

All the relevant operating and safety procedures shall be available to operations personnel. Subcontractor's personnel shall be informed about, and have access to, all relevant safety information.

The vacuum-jacketed piping manufacturer's and/or owner's maintenance procedures shall be available to maintenance personnel. Contractor personnel shall be informed about, and have access to, all the relevant safety information.

8.2 Inspection

At least once per year, it is recommended to inspect the entire length of the piping system from the start to the end-use equipment. The following should be investigated:

- Frost or ice spots—Frost, condensation, or ice can occur for various reasons and at different locations such as:
 - At any uninsulated connections;
 - At bayonet flanges, at certain ambient temperature and humidity conditions; and
 - On piping sections, at certain ambient temperature and humidity conditions.

If frost, ice, or condensation is permanent and/or grows on vacuum-jacketed components, monitor the components and check the vacuum level of that section. See Figure 11 for an example of icing that should be investigated.

- Vacuum pump out ports—Verify that all vacuum pump out ports are in place and not venting. If a vacuum pump out port plug is missing, this could indicate an inner leak that should be investigated immediately. This can be done with a pressure check or a purity check;
- Damage to the vacuum gauge tubes;
- Signs of a cryogenic liquid leak—Visual indications include frosting, venting cold gas, and liquid leaking from joints. In the event that a leak is observed, an oxygen monitor can detect elevated levels that should be investigated immediately with an action plan developed to address the leak;
- Visual damage to the piping such as dents on external bellows. Further action will depend on the cause and extent of the damage;
- Relief valves—When inspecting the valves, check for any signs of the following:
 - Plug, dirt, or debris in the exit of the relief valve
 - Liquid or gas leaking out of the relief valve or from the inlet connection of the relief valve and
 - Periodic control of vacuum level.

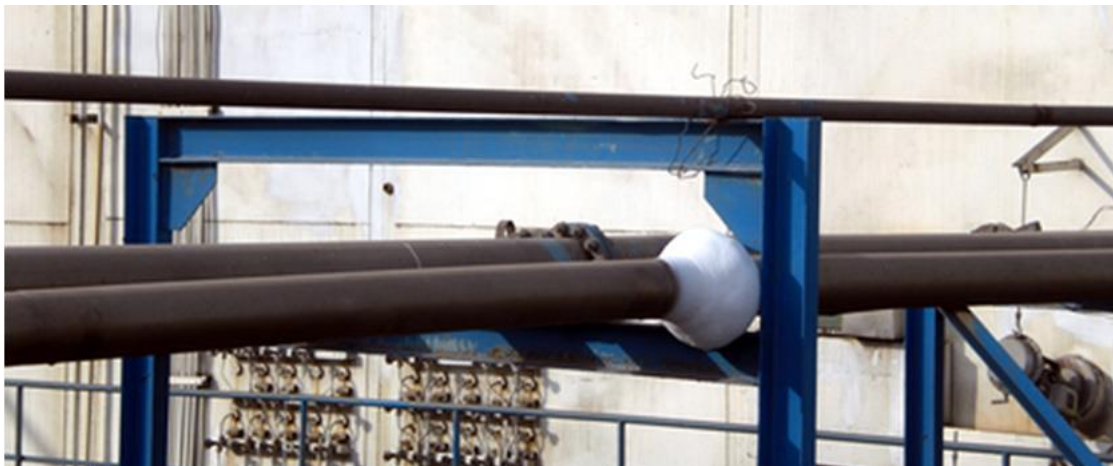

Figure 11 Example of an iced bayonet connection

8.3 Vacuum reading

The vacuum measurement in warm or in cold conditions shall be carried out using an appropriate written procedure.

The level of vacuum shall be checked with an electronic vacuum gauge. If the vacuum measured is:

- Greater than or equal to 100 Pa (1 mbar or 750 μ Hg) or if water condensation or ice is detected on the outer vacuum jacket, the equipment should be investigated, and a plan developed to address the issue. A validated procedure shall be established describing the repair operations including a specific focus on safety issues during the warming phase; and
- Less than 100 Pa (1 mbar or 750 μ Hg):
 - Less than 2 Pa (2×10^{-2} mbar or 15 μ Hg) in cold conditions. The vacuum is suitable for the continuity of service

- Between 2 Pa and 20 Pa (2×10^{-2} mbar and 2×10^{-1} mbar or 15 μ Hg and 150 μ Hg) in cold conditions. The vacuum is degraded and maintenance operations shall be planned; and
- Greater than 20 Pa (2×10^{-1} mbar or 150 μ Hg) in cold conditions. Suspect leakage in the vacuum space and investigate equipment immediately.

8.4 Maintenance

Maintenance personnel shall work with clean hands, work clothing, and gloves that are free of lint, fibres, and uncontaminated by oil or grease. Oxygen wetted parts shall not be touched with bare hands. Personal protective equipment (PPE) requirements are given in AIGA 066, *Selection of Personal Protective Equipment* [16].

Before performing nonroutine work on oxygen systems, a safety work permit should be issued or an equivalent safety procedure in place. Example of precautions include:

- open flames shall be prohibited in the work area; hot work shall only be performed under written work permission;
- ensure removal of all traces of oil and grease;
- cap open pipe ends when not working on the pipe;
- do not ground any equipment such as welding equipment, onto oxygen piping systems while in operation (oxygen under pressure); and
- use tools that are clean and free of grease.

Further information on work permit systems can be found in AIGA 011, *Work Permit Systems* [17].

8.5 Equipment isolation

Lockout/tagout (LOTO) procedures shall be used with positive isolation as necessary when maintenance is undertaken on the oxygen piping system itself.

8.6 Management of change

A management of change (MOC) process shall be followed for any changes made, other than replacement in kind, to the piping system, gaskets, etc. See AIGA 010, *Management of Change* for guidance [18].

An MOC process shall also be followed for any changes in inspection, maintenance, or cleaning procedures.

8.7 Protecting open systems when piping or piping components have been removed

Open pipes or ports shall be protected with oxygen cleaned plugs, caps, or blinds. These plugs, caps, or blinds should be controlled as listed items on a register so that they can all be accounted for when work is complete.

Rags and adhesive tape shall not be used inside pipework or on flange faces. Protected piping should have a nitrogen or dry, oil-free air purge applied to ensure that debris cannot enter the piping and to prevent condensation. Precautions shall be taken when using purges in closed areas or in confined spaces. Assume that purge gas will enter that space, label it, and barrier it accordingly against inadvertent entry by personnel. Asphyxiation hazards shall be managed by an appropriate work permit process, see AIGA 011 [17].

8.8 System blowout after major maintenance

Cleanliness can be divided into two distinct areas:

- free from hydrocarbons; and
- free of particulates.

Cleanliness can only be achieved by rigorous attention to piping components and system build cleanliness as the maintenance is performed. When working in the field, particulate can fall into piping, particularly when vertically orientated. Particulates are not always visible and not easily removed. Accordingly, it is recommended that any oxygen system that has been opened for maintenance is blown out with inert gas or clean, oil-free, dry air wherever possible.

8.9 Change of service

Liquid oxygen vacuum-jacketed piping may be used for other air gas applications following a review to ensure mechanical integrity. However, a change of service of any vacuum-jacketed piping from a nonoxygen service to liquid oxygen service is not permitted unless the piping (all metallic and non-metallic components) is explicitly reviewed, approved, and designated for oxygen service.

9 References

Unless otherwise specified, the latest edition shall apply.

[1] ASTM G63, *Standard Guide for Evaluating Nonmetallic Materials for Oxygen Service*, ASTM International. www.astm.org

[2] AIGA 005, *Fire Hazards of Oxygen and Oxygen-Enriched Atmospheres*, Asia Industrial Gases Association. www.asiaiga.org

NOTE This publication is part of an international harmonisation programme for industry standards. The technical content of each regional document is identical, except for regional regulatory requirements. See the referenced document preface for a list of harmonized regional references.

[3] AIGA 094, *Design, Manufacture, Installation, Operation, and Maintenance of Valves Used in Liquid Oxygen and Cold Gaseous Oxygen Systems*, Asia Industrial Gases Association. www.asiaiga.org

NOTE This publication is part of an international harmonisation programme for industry standards. The technical content of each regional document is identical, except for regional regulatory requirements. See the referenced document preface for a list of harmonized regional references.

[4] AIGA 012, *Cleaning of Equipment for Oxygen Service*, Asia Industrial Gases Association. www.asiaiga.org

NOTE This publication is part of an international harmonisation programme for industry standards. The technical content of each regional document is identical, except for regional regulatory requirements. See the referenced document preface for a list of harmonized regional references.

[5] ASME B31.3, *Process Piping*, American Society of Mechanical Engineers. www.asme.org

[6] ASTM A403, *Standard Specification for Wrought Austenitic Stainless Steel Piping Fittings*, ASTM International. www.astm.org

[7] ASTM B16.9, *Factory Made Wrought Buttwelding Fittings*, ASTM International. www.astm.org

[8] *Standards of the Expansion Joint Manufacturers Association, Inc.*, Expansion Joint Manufacturers Association, Inc. www.ejma.org

[9] *ASME Boiler and Pressure Vessel Code*, American Society of Mechanical Engineers. www.asme.org

[10] Safety Info 23/10, *Fire in Lox Vacuum Jacketed Piping*, European Industrial Gases Association. www.eiga.eu

[11] BS 6501-1, *Metal hose assemblies. Guidance on the construction and use of corrugated hose assemblies*, British Standards Institution (BSI). www.bsigroup.com

[12] ASTM G72, *Standard Test Method for Autogenous Ignition Temperature of Liquids and Solids in a High-Pressure Oxygen-Enriched Environment*, ASTM International. www.astm.org

[13] ASTM G88, *Standard Guide for Designing Systems for Oxygen Service*, ASTM International. www.astm.org

[14] ASTM G86, *Standard Test Method for Determining Ignition Sensitivity of Materials to Mechanical Impact in Ambient Liquid Oxygen and Pressurized Liquid and Gaseous Oxygen Environments*, ASTM International. www.astm.org

[15] ASTM G93, *Standard Practice for Cleaning Methods and Cleanliness Levels for Material and Equipment Used in Oxygen-Enriched Environments*, ASTM International. www.astm.org

[16] AIGA 066, *Selection of Personal Protective Equipment*, Asia Industrial Gases Association. www.asiaiga.org

NOTE This publication is part of an international harmonisation programme for industry standards. The technical content of each regional document is identical, except for regional regulatory requirements. See the referenced document preface for a list of harmonized regional references.

[17] AIGA 011, *Work Permit Systems* Asia Industrial Gases Association. www.asiaiga.org

[18] AIGA 010, *Management of Change*, Asia Industrial Gases Association. www.asiaiga.org

10 Additional references

AIGA 030, *Storage of Cryogenic Air Gases and Users' Premises*, Asia Industrial Gases Association. www.asiaiga.org

EIGA Doc 24, *Vacuum Insulated Cryogenic Storage Tank Systems Protection Devices*, European Industrial Gases Association. www.eiga.eu

EN 13458, *Cryogenic vessels. Static vacuum insulated vessels. Design, fabrication, inspection and testing*, www.cen.eu

ISO 22538-3, *Space systems -- Oxygen safety -- Part 3: Selection of non-metallic materials for oxygen systems and components*, www.iso.org

Appendix A—List of typical suitable materials (Informative)

All non-metallic materials used within the annular space shall pass the liquid oxygen impact test in accordance with ASTM G86 [14].

Component	Typical suitable materials for liquid oxygen service
Inner pipe and inner pipe fittings	300 Series stainless steels Invar 36
Bellows	300 Series stainless steels
Spacers	PTFE PCTFE Other materials provided that the suitability for liquid and gaseous oxygen service has been verified
Outer pipe and outer pipe jacket	300 Series stainless steels
Flexible pipe sections	304, 316L, or 321 stainless steel
Braid	300 Series stainless steel
O-rings	PTFE PCTFE Viton® (bayonet flange)
Band clamps	300 Series stainless steel
Insulation material	Radiation shields made of oil-free aluminium foils and insulating spacers made of inorganic material (for example, Cryotherm 243®, Lydall)
Getter material	Palladium oxide Silver zeolite
Adsorbent material	Molecular sieve (typically Grade 5A)
NOTE Avoid the use of lubricants. Where lubricants are used, ensure they are compatible for use in oxygen service. See 6.1.	